

Coherent structures in a turbulent environment

F. Spineanu and M. Vlad

Association Euratom–CEA sur la Fusion, CEA–Cadarache, F-13108 Saint-Paul-lez-Durance, France
and National Institute for Laser, Plasma and Radiation Physics, P.O. Box MG-36, Magurele, Bucharest, Romania

(Received 8 August 2001; published 25 January 2002)

A systematic method is proposed for the determination of the statistical properties of a field consisting of a coherent structure interacting with turbulent linear waves. The explicit expression of the generating functional of the correlations is obtained, performing the functional integration on a neighborhood in the function space around the soliton. The results show that the non-Gaussian fluctuations observed in the plasma edge can be explained by the intermittent formation of nonlinear coherent structures.

DOI: 10.1103/PhysRevE.65.026406

PACS number(s): 52.35.Ra, 52.35.Sb, 05.20.–y, 05.45.Yv

I. INTRODUCTION

In a recent work [1] it has been proposed a systematic analytical method for the investigation of the statistical properties of a coherent structure interacting with turbulent field. The method is developed here in detail and possible applications or developments arise.

The nonlinearity of the dynamical equations of fluids and plasma is the determining factor in the behavior of these systems. The current manifestation is the generation, from almost all initial conditions, of turbulent states, with an irregular aspect of fluctuations implying a wide range of space-and-time scales. The fluctuations seem to be random and a statistical characterization of the fluctuating fields is appropriate. However, it is known both from theory and experiment that the same fields can have, in particular situations, stable and regular forms that can be identified as coherent structures, for example, solitons and vortices. For most general conditions one should expect that these aspects are both present and this requires to study the mixed state consisting of coherent structures and homogeneous turbulence.

Numerical simulations of magnetohydrodynamics show that in general cases a coherent structure emerges in a turbulent plasma, it moves while deforming due to the interactions with the random fields around it and eventually is destroyed. In plasma turbulence a coherent structure is build up by the inverse spectral cascade or by merging and coalescence of small-scale structures [2–4]. The nonlinearity of the equations for the drift waves in a nonuniform, magnetized plasma permits the formation of solitary waves in addition to the usual small-amplitude dispersive modes. The convective nonlinearity (of the Poisson bracket type), can lead to *low-frequency convective structures* in magnetized plasma [5–9]. The structures are not solitons in the strict sense but are very robust. It is even possible that the state of plasma turbulence can be represented as a superposition of coherent vortex structures (generated by a self-organization process) and weakly correlated turbulent fluctuations.

Naturally, the coherent structures influences the statistical properties of the fields (the correlations), in particular the spectrum. In this context it is usual to say that the deviation of the correlations of the fluctuating fields from the Gaussian statistics is associated with the presence of the coherent

structures and it is named *intermittency*. Numerical simulations [10] of the two-dimensional Navier-Stokes fluid turbulence have shown coherent structures evolving from random initial conditions and in general energy spectra steeper than k^{-3} have been attributed to intermittency (patchy, spatial intermittent patterns). These coherent structures are long lived and disappear only by coalescence, the latter being manifested as spatial intermittency. In these studies it was underlined that the coherent structures have effects that cannot be predicted by closure methods applied to mode-coupling hierarchies of equations.

The difficulty of the analytical description is the absence from theory of well-established technical methods for investigating the plasma turbulence in the presence of coherent structures. While for the instability-induced turbulence (via nonlinear mode coupling), systematic renormalization procedures have been developed, the problem of the simultaneous presence of coherent structures and drift turbulence has not received a comparable detailed description.

In the recently proposed method [1], the starting point is the observation that the coherent structure and the drift waves, although very different in form, are similar from a particular point of view: the first realizes the extremum and the latter is very close to the extremum of the action functional that describes the evolution of the plasma. The analytical framework is developed such as to exploit this feature and is based on results from well-established theories: the functional statistical study of the properties of the classical stochastic dynamical systems (in the Martin-Siggia-Rose approach); the perturbed inverse scattering transform method, allowing to calculate the field of perturbed nonlinear coherent structures; the semiclassical approximation in the study of the quantum particle motion in multiple minima potentials.

The dilute gas of plasma solitons has been studied by Meiss and Horton [11] who assumed a probability density function of the amplitudes characteristic of the Gibbs ensemble. We analyze the same nonlinear equation but take into account the drift wave turbulence.

A brief discussion on the closure methods developed in the study of drift wave turbulence provides us the argumentation for the need of a different approach (Sec. II). Section III contains a description of the general lines of the method proposed. A more technical presentation of the calculation is

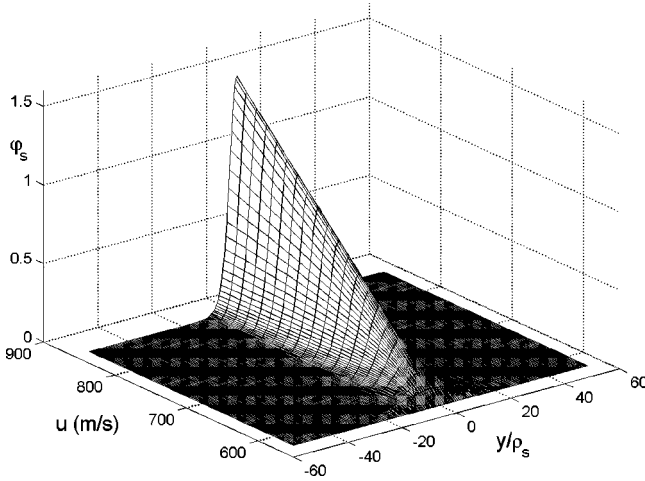

FIG. 1. Variation of the form of the soliton $\varphi_s(y)$ with the velocity, u .

given in Sec. III B. The particular case of the drift wave equation is developed in detail in Sec. IV and in Sec. V the explicit expression of the generating functional is used for the calculation of the correlation functions. The results and the conclusions are presented in the last section. Some details of calculations are given in the Appendix.

II. THE NONLINEAR DYNAMICAL EQUATIONS

We consider the plasma confined in a strong magnetic field and the drift wave electric potential in the transversal plane (x,y) where y corresponds to the poloidal direction and x to the radial one in a tokamak. We shall work with the radially symmetric Flierl-Petviashvili soliton equation [12] studied in Refs. [11,13,14]:

$$(1 - \rho_s^2 \nabla_{\perp}^2) \frac{\partial \varphi}{\partial t} + v_d \frac{\partial \varphi}{\partial y} - v_d \varphi \frac{\partial \varphi}{\partial y} = 0, \quad (1)$$

where $\rho_s = c_s / \Omega_i$, $c_s = (T_e / m_i)^{1/2}$, and the potential is scaled as $\varphi = (L_n / L_{T_e})(e\Phi / T_e)$. Here L_n and L_{T_e} are, respectively, the gradient lengths of the density and temperature. The velocity is the diamagnetic velocity $v_d = \rho_s c_s / L_n$. The condition for the validity of this equation is $(k_x \rho_s)(k \rho_s)^2 \ll \eta_e (\rho_s / L_n)$, where $\eta_e = L_n / L_{T_e}$.

The exact solution of the equation is

$$\varphi_s(y, t; y_0, u) = -3 \left(\frac{u}{v_d} - 1 \right) \operatorname{sech}^2 \left[\frac{1}{2\rho_s} \left(1 - \frac{v_d}{u} \right)^{1/2} \times (y - y_0 - ut) \right], \quad (2)$$

where the velocity is restricted to the intervals $u > v_d$ or $u < 0$. The function is represented in Fig. 1. In Ref. [11] the radial extension of the solution is estimated as $(\Delta x)^2 \sim \rho_s L_n$. In our work we shall assume that u is very close to v_d , $u \gtrsim v_d$ (i.e., the solitons have small amplitudes).

The nonlinear equations for the drift waves are known to generate as solutions irregular turbulent fields, but also exact

coherent structures of the type (2), depending on the initial conditions. Typical statistical quantities are the correlations, such as $\langle \varphi(x, y, t) \varphi(x', y', t') \rangle \sim |\mathbf{x} - \mathbf{x}'|^{\zeta} |t - t'|^z$, where for the homogeneous turbulence the exponents ζ and z are calculated by the theory of renormalization or by spectral balance equations, using closure methods [15]. Various closure methods have been developed as perturbations around Gaussianity and they are valid for small deviation from the Gaussian statistics (for a detailed review, see Ref. [16]). We see intuitively that this approach cannot be extended to the description of the coherent structures. This can also be seen in more analytical terms. A quantity that is unavoidable in the calculation of the correlations is the average of the exponential of a functional of the fluctuating field, consider simply $\langle \exp(\varphi) \rangle$ (for example, in the inverse of the Vlasov operator, using the Fourier transformation, the potential appears in the formal expression of the trajectory, i.e., at the exponent). This quantity can be written schematically as [16]

$$\langle \exp(\varphi) \rangle = \exp \left[\sum_n \frac{1}{n!} \langle \langle \varphi^n \rangle \rangle \right], \quad (3)$$

where $\langle \langle \varphi^n \rangle \rangle$ represents the cumulant of order n (i.e., the irreducible part of the correlation, after subtracting the combinations of the lower order cumulants). For Gaussian statistics the first two cumulants are different from zero ($n=1$, average and $n=2$, dispersion), all others are zero. Nonvanishing of the higher order cumulants is the signature of non-Gaussian statistics. In the perturbative renormalization we assume slight deviation from Gaussianity, i.e., small absolute values of the next order cumulants (e.g., the kurtosis must be close to 3, the Gaussian value) and vanishing of the higher order cumulants. This assumption is obviously invalid in the case of coherent structures. The field of a coherent structure has long range, persistent correlations imposed by its regular geometry, which naturally requires nonvanishing very large order cumulants [i.e., many terms in the sum at the exponent in Eq. (3)] and excludes any perturbative expansion.

In particular, the closure of the nonlinear equation for the two-point correlation (based on the retaining the directly interacting triplet) can account for the small-scale correlations related to the space-dependent relative diffusion, i.e., the clump effect [15,17,18], but the spectrum obtained in this framework cannot account for the possible existence of the coherent structures. This clearly suggests that we must find a different approach.

III. COHERENT STRUCTURES IN A TURBULENT BACKGROUND

A. The outline of the method

We present the basic lines of an approach that can provide a statistical description of the coherent structure in a turbulent background. The physical origin of this approach is the observation that the nonlinear equation whose solution is the coherent structure (the vortex soliton) also has classical drift waves as solutions, in the case of very weak nonlinearity. In a certain sense (that will become more clear further on), the vortex soliton and the drift waves belong to the same family

of dynamical configurations of the plasma. Our approach, which is designed to put in evidence and to exploit this property, consists of the following steps.

We start by constructing the action functional of the system. The dynamical equation is the Euler-Lagrange equation derived from the condition of extremum of this functional and the exact solution is the vortex soliton (2).

By using the exponential of the action we construct the generating functional of the irreducible correlations of φ . This functional contains all the information on the coherent structure and the drift turbulence. The correlations are obtained via functional differentiations. This requires the formal introduction of a perturbation of the system, through the interaction with an external current. Throughout the work, this perturbation will be considered a small quantity and finally it will be taken zero.

The generating functional is by definition a functional integral over all possible configurations of the system and this integral must be calculated explicitly. The simplest thing to do is to determine the configuration of the system (with space and time dependence) that extremises the action, by equating the first functional variation of the action with zero and solving this equation, this will give the vortex soliton (modified due to the small interaction term). Then one should replace this solution in the expression of the action. This is the lowest approximation and it does not contain anything related to the drift wave turbulence.

At this point we can benefit from the particular physics of the drift waves. The vortex soliton is the exact solution of the fully nonlinear equation and is a localized potential perturbation with regular, cylindrical symmetric form. The linear drift waves are harmonic potential perturbations propagating with constant velocity (the diamagnetic velocity in the case of the drift poloidal propagation in tokamak). Although the drift waves have very different geometry they are solutions of the same equation as the vortex, but for negligible magnitude of the nonlinear term. The drift waves do not exactly realize the extremum of the action functional, but obtain an action very close to this extremum. This means that the drift waves and the vortex soliton are close in the function space in the sense of the measure defined by the exponential of the action. In other terms the drift waves are in a functional neighborhood of the vortex (for this measure). This suggests to perform the functional integral with better approximation, which means to perform the integration over a functional neighborhood of the vortex solution. This will automatically include the drift waves in the generating functional of correlation that so will contain information on both the coherent structure and the drift waves. The function space neighborhood over which the functional integration is extended is limited by the measure (exponential of the action) that severely penalizes all configurations of the system that are far from the solution realizing the extremum (i.e., the vortex soliton). As in any stationary phase method there are oscillations that strongly suppress the contribution of the configurations that are far (in the sense of the measure) from the soliton. In practice we shall expand the action in a functional Taylor series around the soliton solution and keep the term with the second functional derivative.

In this perspective the drift waves appear as fluctuations around the soliton solution. This is compatible with the numerical simulations that show that the vortices are accompanied by a tail of drift waves. During the interaction of the vortices linear drift waves are “radiated” [19]. On the other hand, the analytical treatment of the perturbed vortex solution by the perturbed inverse scattering transform shows similar tail of perturbed field, following the soliton. This strengthens our argument that integrating close to the vortex means to include the drift waves in the generating functional.

The functional integral can be performed exactly and we determine the generating functional of the potential correlations. We shall calculate the two-point correlation by performing double functional derivative at the external current.

B. Expansion around a soliton

1. The action and the generating functional of the correlations

The analytical framework is similar to the model of quantum fluctuations around the instanton solution in the semi-classical calculation of the transition amplitude for the particle in a two-well potential (see Ref. [20]). Let us write formally the equation for a nonlinear plasma waves as

$$\hat{O}\varphi = 0, \quad (4)$$

where the field $\varphi(x,y,t)$ represents the “field” (coherent structure and drift waves) and the operator \hat{O} is the nonlinear operator of the Eq. (1). This equation should be derived from the condition of extremum of an action functional that must reflect the statistical nature of our problem. The field φ obeys a purely deterministic equation, but the randomness of the initial conditions generates a statistical ensemble of realizations of the system evolutions (space-time configurations). We shall follow the Martin-Siggia-Rose method of constructing the action functional but in the path-integral formalism, for which we give in the following a very short description [21–25]. First, we consider a formal extension from the statistical ensemble of realizations of the system’s space-time configurations to a larger space of functions that may include even nonphysical configurations. Every function is discretized in space and time, so it will be represented as a collection of variables φ_i , each attached to the corresponding space-time point i . In this space of functions, the selection of the configurations that correspond to the physical ones (solutions of the equation of motion) is performed through the identification with Dirac δ functions, in every space-time point

$$\prod_i \delta(\varphi_i - \varphi(x_i, y_i, t_i)) \delta(\hat{O}\varphi), \quad (5)$$

and integration over all possible functions φ , i.e., over the ensemble of independent variables φ_i . Using the Fourier representation for every δ function we get

$$\int \prod_i d\varphi_i \int \prod_i d\chi_i \exp[i\chi_i \hat{O}\varphi(x_i, y_i, t_i)]. \quad (6)$$

Going to the continuum limit, a new function $\chi(x, y, t)$, appears which is similar to the Fourier conjugate of φ . The generating functional of the correlation functions is

$$Z = \int D[\varphi(\mathbf{x}, t)] D[\chi(\mathbf{x}, t)] \times \exp\left\{i \int d\mathbf{x}' dt' \chi(\mathbf{x}', t') \hat{O} \varphi(\mathbf{x}', t')\right\}, \quad (7)$$

where the functional measures have been introduced and $\mathbf{x} \equiv (x, y)$.

The random initial conditions $\varphi_0(y)$ can be included by a Dirac δ functional $\delta(\varphi(t_0, y) - \varphi_0(y))$. As explained in [1], instead of this exact treatment (accessible only numerically) we exploit the particularity of our approach, i.e., the connection between the functional integration and the delimitation of the statistical ensemble; the way we perform the functional integration is an implicit choice of the statistical ensemble. We choose to build implicitly the statistical ensemble, collecting all configurations that have the same type of deformations (given in our formulas by $\tilde{\chi}_{\mathbf{J}}$). All these configurations belong to the neighborhood of the extremum in function space and we take them into account, by performing the integration over this space. In doing so we assume that the ensemble of perturbed configurations induced by an “external” excitation (\mathbf{J} below) of the system is the same as the statistical ensemble of the system’s configurations evolving from random initial conditions.

We must add to the expression in the integrand at the exponential a linear combination related to the interaction of the fields φ and χ with external currents J_φ and J_χ

$$Z \rightarrow Z_{\mathbf{J}} = \int D[\varphi(\mathbf{x}, t)] D[\chi(\mathbf{x}, t)] \exp\{i S_{\mathbf{J}}\}, \quad (8)$$

$$S_{\mathbf{J}} \equiv \int d\mathbf{x}' dt' [\chi(\mathbf{x}', t') \hat{O} \varphi(\mathbf{x}', t') + J_\varphi \varphi + J_\chi \chi].$$

It is now possible to obtain correlations by functional differentiation, for example,

$$\begin{aligned} & \langle \varphi(x_2, y_2, t_2) \varphi(x_1, y_1, t_1) \rangle \\ &= \frac{1}{Z_{\mathbf{J}}} \frac{\delta^2 Z_{\mathbf{J}}}{\delta J_\varphi(x_2, y_2, t_2) \delta J_\varphi(x_1, y_1, t_1)} \Big|_{\mathbf{J}=0}. \end{aligned} \quad (9)$$

For the explicit calculation of the generating functional we need the functions φ and χ , which extremize the action

$$\frac{\delta S_{\mathbf{J}}}{\delta \varphi} = 0 \quad (10)$$

$$\frac{\delta S_{\mathbf{J}}}{\delta \chi} = 0.$$

2. Schema of calculation of the generating functional

In the absence of the current \mathbf{J} the Eqs. (10) have as solutions for φ the nonlinear solitons (vortices) [26,27]. and

More generally, the basic solution of the *KdV* equation (on which the Flierl-Petviashvili equation can be mapped) is the periodic cnoidal function that becomes, when the modulus of the elliptic function is close to 1, the soliton. When the distance between the centers of the solitons is much larger than their spatial extension (dilute gas) the general solution can be written as a superposition of individual solitons, with different velocities and different positions [11]. For simplicity we shall consider in this work a single vortex soliton and in the last section we shall comment on the extension of the method to many solitons.

The position of the center of the soliton rises the difficult problem of the *zero modes* [20]. Except for a brief comment about the relation of the zero modes with the Gaussian functional integration (see below), we shall avoid this problem and postpone the discussion of this topic to a future work.

In the presence of the external current \mathbf{J} , the equations resulting from the extremization of the action $S_{\mathbf{J}}$ become inhomogeneous, and the solutions are *perturbed* solitons. This point is technically nontrivial and we shall use the results obtained by Karpman [28] who considered the inverse scattering transform method applied to the perturbed soliton equation. We find the approximate solution $\varphi_{\mathbf{J}_s}$ and $\chi_{\mathbf{J}_s}$ of the inhomogeneous equations (i.e., including the external current \mathbf{J}). The result depends on the currents \mathbf{J} , and this will permit us to perform functional differentiations in order to calculate the correlation, as shown in Eq. (9). As a first step in obtaining the explicit form of $Z_{\mathbf{J}}$, the perturbed soliton solutions depending on \mathbf{J} must be introduced in the expression of the action $S_{\mathbf{J}}$. After that we perform the expansion of the functions φ and χ around the coherent solution,

$$\varphi = \varphi_{\mathbf{J}_s} + \delta\varphi, \quad (11)$$

$$\chi = \chi_{\mathbf{J}_s} + \delta\chi.$$

This gives

$$\begin{aligned} Z_{\mathbf{J}} &= \exp(i S_{\mathbf{J}_s}) \int D[\delta\varphi] D[\delta\chi] \exp\left\{ \int d\mathbf{x}' dt' \delta\chi(\mathbf{x}', t') \right. \\ &\quad \left. \times \left(\frac{\delta^2 \hat{O}}{\delta\varphi \delta\chi} \Big|_{\varphi_{\mathbf{J}_s}, \chi_{\mathbf{J}_s}} \right) \delta\varphi(\mathbf{x}', t') \right\} \end{aligned}$$

or

$$Z_{\mathbf{J}} = \exp(i S_{\mathbf{J}_s}) \frac{1}{2^n i^n} (2\pi)^{n/2} \left(\det \frac{\delta^2 \hat{O}}{\delta\varphi \delta\chi} \Big|_{\varphi_{\mathbf{J}_s}, \chi_{\mathbf{J}_s}} \right)^{-1/2}, \quad (12)$$

since the integral is Gaussian [23]. The determinant is calculated using the eigenvalues

$$\left(\frac{\delta^2 \hat{O}}{\delta\varphi \delta\chi} \Big|_{\varphi_{\mathbf{J}_s}, \chi_{\mathbf{J}_s}} \right) \psi_n(\mathbf{x}, t) = \lambda_n \psi_n(\mathbf{x}, t) \quad (13)$$

$$\det\left(\frac{\delta^2 \hat{O}}{\delta\varphi \delta\chi}\bigg|_{\varphi_{\mathbf{J}_s}, \chi_{\mathbf{J}_s}}\right) = \prod_n \lambda_n. \quad (14)$$

Since the action is invariant to the arbitrary position of the center of the soliton there are directions in the function space where the fluctuations are not bounded and, in particular, are not Gaussian. This requires the introduction of a set of collective coordinates and after a change of variables the functional integrations along those particular directions are replaced by usual integrations over the collective variables, with inclusion of Jacobian factors. The zero eigenvalues of the determinant (corresponding to the *zero modes*) are excluded in this way. We shall avoid this complicated problem and assume a given position for the center of the vortex.

IV. APPLICATION TO THE VORTEX SOLUTION OF THE NONLINEAR DRIFT WAVE

A. The action functional

In order to adimensionalize Eq. (1) we introduce the space-and-time scales $t \rightarrow \Omega^{-1}t$ and $y \rightarrow \rho_s y$ and the equation becomes

$$(1 - \nabla_{\perp}^2) \frac{\partial \varphi}{\partial t} + \left(\frac{v_d}{\Omega \rho_s}\right) \frac{\partial \varphi}{\partial y} - \left(\frac{v_d}{\Omega \rho_s}\right) \varphi \frac{\partial \varphi}{\partial y} = 0. \quad (15)$$

For simplicity of notation we keep the symbol v_d for the adimensional velocity ($v_d/\Omega \rho_s$). The equation does not change in form but now all variables are adequately normalized, and the *action*

$$S = \int dy dt L_{\varphi} \quad (16)$$

is also adimensional.

We have to calculate explicitly the scalar function χ . Based on the extended knowledge developed in field theory it seems reasonable to assume that this function represents the generalization of the functions that have the opposite evolution compared to φ : if φ evolves toward infinite time, then χ comes from infinite time toward the initial time. If φ diffuses then χ antidiffuses (see Ref. [30]). The general characteristics of this behavior suggest to represent χ as the object with the opposite topology than φ . If φ has a certain topological class, then χ has the opposite topological class. If φ is an instanton then χ is an anti-instanton. In our case, if φ is the vortex solution, then χ must be the ‘‘antivortex’’ solution, with opposite vorticity everywhere compared to φ . In our case of a single vortex, χ must simply be a negative vortex.

In general terms, the direct (i.e., the vortex and random drift waves) solution φ arises from an initial perturbation that evolving in time breaks into several distinct vortices (solitons) and a tail of drift waves, as shown by the inverse scattering method. The functionally conjugated (‘‘regressive’’) function χ is at $t = \infty$ a collection of vortices and drift wave turbulence that evolving backward in time, toward $t = 0$, coalesce and build up into a single perturbation, the same as the initial condition of φ . We can restrict our analysis to the time

range where the two functions have similar patterns (but opposite), which simply means to choose the time interval far from the initial and asymptotic limits. As shown by analytical and numerical studies, the vortices (positive and negative) are robust patterns and the time evolution simply consists of translations without decay. In conclusion we can take for the time range far from the boundaries $t = 0$ and $t = T$,

$$\chi = -\varphi. \quad (17)$$

To see this more clearly, we write down the action and then the Euler-Lagrange equations, with the current \mathbf{J} included.

$$S_{\mathbf{J}}[\chi, \varphi] = \int_0^L dy \int_0^T dt L_{\mathbf{J}, \varphi} \quad (18)$$

with the notation

$$L_{\mathbf{J}, \varphi} = \chi \left[(1 - \nabla_{\perp}^2) \frac{\partial \varphi}{\partial t} + v_d \frac{\partial \varphi}{\partial y} - v_d \varphi \frac{\partial \varphi}{\partial y} \right] + J_{\varphi} \varphi + J_{\chi} \chi. \quad (19)$$

When performing integrations by parts the boundary conditions of the two functions prevents us from taking the integrals of exact differentials as vanishing, but this just produces terms that do not contribute to the determination of the solution of extremum. We shall first change the Eq. (19) such as to obtain by functional extremization an (Euler-Lagrange) equation for the function χ

$$L_{\mathbf{J}, \varphi}^{(1)} = \chi \frac{\partial \varphi}{\partial t} - [\nabla_{\perp}^2 \chi] \frac{\partial \varphi}{\partial t} + v_d \chi \frac{\partial \varphi}{\partial y} - v_d \chi \varphi \frac{\partial \varphi}{\partial y} + J_{\varphi} \varphi + J_{\chi} \chi. \quad (20)$$

Now we write the condition of extremum for the action functional and obtain the Euler-Lagrange equation

$$\frac{d}{dt} \frac{\delta L_{\mathbf{J}, \varphi}^{(1)}}{\delta \left(\frac{\partial \varphi}{\partial t}\right)} + \frac{d}{dx} \frac{\delta L_{\mathbf{J}, \varphi}^{(1)}}{\delta \left(\frac{\partial \varphi}{\partial x}\right)} + \frac{d}{dy} \frac{\delta L_{\mathbf{J}, \varphi}^{(1)}}{\delta \left(\frac{\partial \varphi}{\partial y}\right)} - \frac{\delta L_{\mathbf{J}, \varphi}^{(1)}}{\delta \varphi} = 0. \quad (21)$$

This equation can be written as

$$(1 - \nabla_{\perp}^2) \frac{\partial \chi}{\partial t} + v_d \frac{\partial \chi}{\partial y} - v_d \chi \frac{\partial \chi}{\partial y} = J_{\varphi}. \quad (22)$$

An equivalent form of the action is

$$S_{\mathbf{J}}[\chi, \varphi] = \int_0^L dy \int_0^T dt L_{\mathbf{J}, \chi} \quad (23)$$

with

$$L_{\mathbf{J}, \chi} = -\varphi \frac{\partial \chi}{\partial t} + (\nabla_{\perp}^2 \varphi) \frac{\partial \chi}{\partial t} - v_d \varphi \frac{\partial \chi}{\partial y} + v_d \frac{\varphi^2}{2} \frac{\partial \chi}{\partial y} + J_{\varphi} \varphi + J_{\chi} \chi. \quad (24)$$

The equation Euler-Lagrange for the function χ is obtained from the extremum condition on the functional Eq. (23)

$$\frac{d}{dt} \frac{\delta L_{J,\chi}}{\delta \left(\frac{\partial \chi}{\partial t} \right)} + \frac{d}{dx} \frac{\delta L_{J,\chi}}{\delta \left(\frac{\partial \chi}{\partial x} \right)} + \frac{d}{dy} \frac{\delta L_{J,\chi}}{\delta \left(\frac{\partial \chi}{\partial y} \right)} - \frac{\delta L_{J,\chi}}{\delta \chi} = 0. \quad (25)$$

This equation reproduces the nonlinear vortex equation with an inhomogeneous term

$$(1 - \nabla_{\perp}^2) \frac{\partial \varphi}{\partial t} + v_d \frac{\partial \varphi}{\partial y} - v_d \varphi \frac{\partial \varphi}{\partial y} = -J_{\chi}. \quad (26)$$

Comparing the *homogeneous* Eqs. (22) (with $J_{\varphi}=0$) and (26) (with $J_{\chi}=0$) we see that

$$\chi = -\varphi, \quad (27)$$

is indeed the solution of the *homogeneous* Eq. (22), i.e., the negative vortex is the solution for χ .

We must remember that the “external” currents are arbitrary and later, after functional differentiation, they will be taken zero. This allows us to start from the configurations given by the *homogeneous* equations and Eq. (27) and study the small changes using perturbative methods developed in the framework of the inverse scattering transform. We will only use the current J_{φ} that will be denoted J and already take $J_{\chi}=0$.

The final form of the action that will be used later in this work is

$$S_J[\chi, \varphi] = \int_0^L dy \int_0^T dt \left\{ \chi (1 - \nabla_{\perp}^2) \frac{\partial \varphi}{\partial t} + v_d \chi \frac{\partial \varphi}{\partial y} \right. \\ \left. \times -v_d \chi \varphi \frac{\partial \varphi}{\partial y} + J \varphi \right\}. \quad (28)$$

B. The condition of extremum of the action functional

The Euler-Lagrange equations for the two functions χ and φ are obtained from the first functional derivative of the action S_J : $\delta S_J / \delta \chi = 0$ and $\delta S_J / \delta \varphi = 0$. The first equation (which is the original equation) has the solution (2). It does not depend on the current J (since the corresponding current J_{χ} has been taken zero). However, for uniformity of notation we shall write φ_{J_s} ,

$$\varphi_{J_s}(x, y, t) \equiv \varphi_s(x, y, t). \quad (29)$$

The second Euler-Lagrange equation is the equation for χ , with the inhomogeneous term given by the current J :

$$(1 - \nabla_{\perp}^2) \frac{\partial \chi}{\partial t} + v_d \frac{\partial \chi}{\partial y} - v_d \varphi \frac{\partial \chi}{\partial y} = J. \quad (30)$$

The solution is

$$\chi_{J_s}(x, y, t) = -\varphi_s(x, y, t) + \tilde{\chi}_J(x, y, t), \quad (31)$$

where $-\varphi_s(x, y, t)$ represents the “free” solution of the variational equation, i.e., the negative vortex (antisoliton) and $\tilde{\chi}_J(x, y, t)$ is the small modification induced by an inhomogeneous small term, $J(x, y, t)$. Since the function $\tilde{\chi}_J(x, y, t)$ is the perturbation of the negative-vortex solution we will use the Eq. (26) but with the opposite current (i.e., $-J$ instead of J), as Eq. (30) requires.

C. Second order functional expansion and the eigenvalue problem for the calculation of the determinant

Now we shall expand the action $S_J[\varphi]$ to second order around the saddle-point solution. Write

$$\varphi = \varphi_{J_s} + \delta\varphi, \quad (32)$$

$$\chi = \chi_{J_s} + \delta\chi,$$

where the function $(\delta\varphi, \delta\chi)$ is a small difference from the extremum solution. The expanded form of the action will be written as

$$S_J[\chi, \varphi] = S_J[\varphi_{J_s}, \chi_{J_s}] + \frac{1}{2} \left(\frac{\delta^2 S_J}{\delta \varphi \delta \chi} \Big|_{\varphi_{J_s}, \chi_{J_s}} \right) \delta\varphi \delta\chi,$$

where obviously the absence of the linear term is due to the fact that $(\varphi_{J_s}, \chi_{J_s})$ is the solution at the extremum and

$$S_J[\varphi_{J_s}, \chi_{J_s}] = \int_0^L dy \int_0^T dt \left[\chi_{J_s} \frac{\partial \varphi_{J_s}}{\partial t} - (\nabla_{\perp}^2 \chi_{J_s}) \frac{\partial \varphi_{J_s}}{\partial t} \right. \\ \left. + v_d \chi_{J_s} \frac{\partial \varphi_{J_s}}{\partial y} - v_d \chi_{J_s} \varphi_{J_s} \frac{\partial \varphi_{J_s}}{\partial y} + J \varphi_{J_s} \right]. \quad (33)$$

Few manipulations are necessary to make the second functional variation of S_J symmetric in $\delta\varphi$ and $\delta\chi$. Again this will imply boundary terms, but these are now zero since the variations $\delta\varphi$ and $\delta\chi$ vanish at the limits of the space-time domain, by definition. The transformations are simply integrations by parts and give

$$\frac{1}{2} \delta\chi \left(\frac{\delta^2 S_J}{\delta \varphi \delta \chi} \Big|_{\varphi_{J_s}, \chi_{J_s}} \right) \delta\varphi = \frac{1}{2} \delta\varphi \delta\chi \begin{pmatrix} \hat{\gamma} & -\hat{\alpha} - \hat{\beta} \\ \hat{\alpha} - \hat{\beta} & 0 \end{pmatrix} \\ \times \begin{pmatrix} \delta\varphi \\ \delta\chi \end{pmatrix}, \quad (34)$$

where

$$\hat{\alpha} = (1 - \nabla_{\perp}^2) \frac{\partial}{\partial t} + v_d \frac{\partial}{\partial y} - v_d \left(\frac{\partial \varphi_{J_s}}{\partial y} \right), \quad (35)$$

$$\hat{\beta} = \frac{1}{2} v_d \left(\frac{\partial \varphi_{J_s}}{\partial y} \right),$$

$$\hat{\gamma} = -2v_d \chi_{J_s} \frac{\partial}{\partial y}.$$

In the generating functional of the correlations, the expansion gives, after performing the Gaussian integral

$$Z_J = \exp(iS_J) \frac{1}{i^n} (2\pi)^{n/2} \left[\det \left(\frac{\delta^2 S_J}{\delta\varphi \delta\chi} \Big|_{\varphi_{J_s}, \chi_{J_s}} \right) \right]^{-1/2}. \quad (36)$$

As stated before, the det will be calculated as the product of the eigenvalues λ_n

$$\det \left(\frac{\delta^2 S_J}{\delta\varphi \delta\chi} \Big|_{\varphi_{J_s}, \chi_{J_s}} \right) = \prod_n \lambda_n. \quad (37)$$

We must find the eigenvalues of the differential operator appearing in Eq. (34)

$$\begin{pmatrix} \hat{\gamma} & -\hat{\alpha} - \hat{\beta} \\ \hat{\alpha} - \hat{\beta} & 0 \end{pmatrix} \begin{pmatrix} \psi_n^\varphi \\ \psi_n^\chi \end{pmatrix} = \lambda_n \begin{pmatrix} \psi_n^\varphi \\ \psi_n^\chi \end{pmatrix}, \quad (38)$$

which gives the following equation

$$\left[\hat{\gamma} - \frac{1}{\lambda_n} (\hat{\alpha}^2 + \hat{\beta} \hat{\alpha} - \hat{\alpha} \hat{\beta} - \hat{\beta}^2) \right] \psi_n^\varphi = \lambda_n \psi_n^\varphi. \quad (39)$$

The functions $\delta\varphi(y, t)$ and $\delta\chi(y, t)$ represent the differences between the solutions at extremum (solitons) and other functions that are in a neighborhood (in the function space) of the solitons. According to the discussion above, the functions that are ‘‘close’’ to the solitons, for the Flierl-Petviashvili equation are drift waves. For this reason the operator that represents the dispersion (i.e., ∇_\perp^2) will be replaced with its simplest form, $-\bar{k}_\perp^2$ for these waves, with \bar{k}_\perp representing an average normalized wave number for the pure drift turbulence. However, the operator will be retained when applied on the functions related to solitons, since these solutions owe their existence to the balance of nonlinearity and dispersion. The following detailed expressions are obtained for the operators involved in this equation:

$$\begin{aligned} \hat{\alpha}^2 &= \left[(1 - \nabla_\perp^2) \frac{\partial}{\partial t} + v_d \frac{\partial}{\partial y} - v_d \left(\frac{\partial \varphi_{J_s}}{\partial y} \right) \right]^2 = (1 + \bar{k}_\perp^2)^2 \left(\frac{\partial}{\partial t} \right)^2 \\ &\quad - v_d \left[(1 - \nabla_\perp^2) \frac{\partial \varphi_{J_s}}{\partial t} \right] \frac{\partial}{\partial y} + v_d (1 - \varphi_{J_s}) (1 + \bar{k}_\perp^2) \frac{\partial^2}{\partial t \partial y} \\ &\quad + v_d (1 - \varphi_{J_s}) (1 + \bar{k}_\perp^2) \frac{\partial^2}{\partial y \partial t} - v_d^2 (1 - \varphi_{J_s}) \left(\frac{\partial \varphi_{J_s}}{\partial y} \right) \frac{\partial}{\partial y} \\ &\quad + v_d^2 (1 - \varphi_{J_s})^2 \frac{\partial^2}{\partial y^2}, \end{aligned} \quad (40)$$

$$\hat{\beta} \hat{\alpha} = \frac{1}{2} v_d \left(\frac{\partial \varphi_{J_s}}{\partial y} \right) (1 + \bar{k}_\perp^2) \frac{\partial}{\partial t} + \frac{1}{2} v_d^2 \left(\frac{\partial \varphi_{J_s}}{\partial y} \right) (1 - \varphi_{J_s}) \frac{\partial}{\partial y}, \quad (41)$$

$$\begin{aligned} \hat{\alpha} \hat{\beta} &= \frac{1}{2} v_d \left[(1 - \nabla_\perp^2) \frac{\partial^2 \varphi_{J_s}}{\partial t \partial y} \right] + \frac{1}{2} v_d^2 (1 - \varphi_{J_s}) \left(\frac{\partial^2 \varphi_{J_s}}{\partial y^2} \right) \\ &\quad + \frac{1}{2} v_d^2 (1 - \varphi_{J_s}) \left(\frac{\partial \varphi_{J_s}}{\partial y} \right) \frac{\partial}{\partial y} + \frac{1}{2} v_d \left(\frac{\partial \varphi_{J_s}}{\partial y} \right) (1 + \bar{k}_\perp^2) \frac{\partial}{\partial t}, \end{aligned} \quad (42)$$

$$\hat{\beta}^2 = \frac{1}{4} v_d^2 \left(\frac{\partial \varphi_{J_s}}{\partial y} \right)^2. \quad (43)$$

The square brackets are used to underline that the differential operators are not acting outside and the only operation is multiplication. We use the equation verified by φ_{J_s} to make the following replacement:

$$\left[(1 - \nabla_\perp^2) \frac{\partial \varphi_{J_s}}{\partial t} \right] = -v_d (1 - \varphi_{J_s}) \left(\frac{\partial \varphi_{J_s}}{\partial y} \right). \quad (44)$$

The equation becomes

$$\begin{aligned} & - \left\{ (1 + \bar{k}_\perp^2)^2 \frac{\partial^2}{\partial t^2} + 2(1 + \bar{k}_\perp^2) v_d (1 - \varphi_{J_s}) \frac{\partial^2}{\partial y \partial t} \right. \\ & \quad \left. + v_d^2 (1 - \varphi_{J_s})^2 \frac{\partial^2}{\partial y^2} - \frac{3}{4} v_d^2 \left(\frac{\partial \varphi_{J_s}}{\partial y} \right)^2 \right\} \psi_n^\varphi \\ & \quad + \lambda_n \left(-2 v_d \chi_{J_s} \frac{\partial}{\partial y} \right) \psi_n^\varphi = \lambda_n^2 \psi_n^\varphi. \end{aligned} \quad (45)$$

We now take into account the propagating nature of the drift waves and make the change of variables $t \rightarrow t$ and $y \rightarrow y - v_d t$, i.e., we change to the system of reference moving with the diamagnetic velocity. We simplify the equation assuming that the most important space-time variation is wave-like and replace $\partial/\partial t = -v_d(\partial/\partial y)$. By this change of variables the soliton will not be at rest in the new reference system, but it will move very slowly since we have assumed that $u \gtrsim v_d$. We make another approximation by neglecting the slow motion of the soliton. This restricts us to the wave number spectrum but considerably simplifies the calculations. The space variable that will be denoted again y measures the space from the fixed center of the soliton, in the moving system. The difference between the KdV soliton, which is one dimensional and depends exclusively on y and the vortex that is a two-dimensional structure will be considered in the simplest form as described by the estimation of Meiss and Horton for the x extension of the vortex. For convenience we suppress the index n and replace ψ_n^φ by q .

$$\begin{aligned} & \left\{ [(1 + \bar{k}_\perp^2) v_d - v_d (1 - \varphi_{J_s})]^2 \frac{\partial^2}{\partial y^2} + (2\lambda v_d \chi_{J_s}) \frac{\partial}{\partial y} \right. \\ & \quad \left. + \left[\lambda^2 - \frac{3}{4} v_d^2 \left(\frac{\partial \varphi_{J_s}}{\partial y} \right)^2 \right] \right\} q = 0. \end{aligned} \quad (46)$$

We have a suggestive confirmation that the generating function Z_J (via the action S_J) potentially contains configu-

rations of the system consisting of simple drift waves. A perturbation consisting of drift waves and propagating with the diamagnetic velocity v_d is an approximate solution of the original equation for small amplitude (i.e., small nonlinearity). Due to its particular structure, the Martin-Siggia-Rose action functional is exactly zero when calculated with the exact solution, in the absence of any external current J . The action expanded to the second order then gives, for no vortex ($\varphi_{Js}=0$, $\chi_{Js}=0$)

$$\left[\frac{\partial^2}{\partial y^2} + \left(\frac{\lambda}{\bar{k}_\perp^2 v_d} \right)^2 \right] q = 0, \quad (47)$$

which implies periodic oscillations in the space variable y with (recall that everything is adimensional)

$$\lambda = k_y v_d (\bar{k}_\perp^2). \quad (48)$$

Returning to the Eq. (46), we write it in the following form:

$$\left(\frac{\partial^2}{\partial y^2} + A \frac{\partial}{\partial y} + B \right) q = 0, \quad (49)$$

where

$$A \equiv \frac{2\lambda}{v_d} \frac{\chi_{Js}}{(\bar{k}_\perp^2 + \varphi_{Js})^2}, \quad (50)$$

$$B \equiv \frac{\frac{\lambda^2}{v_d^2} - \frac{3}{4} \left(\frac{\partial \varphi_{Js}}{\partial y} \right)^2}{(\bar{k}_\perp^2 + \varphi_{Js})^2}.$$

Now we make the standard transformation of the unknown function

$$q = w \exp\left(-\frac{1}{2} \int^y A(y') dy'\right) \quad (51)$$

and obtain

$$w'' + \left(B - \frac{A'}{2} - \frac{A^2}{4} \right) w = 0, \quad (52)$$

where prime means derivation with respect to y . After replacing the two extremum solutions φ_{Js} and χ_{Js} from Eqs. (29) and (31), this equation is written in the following form to exhibit the dependence on λ :

$$w'' + (\lambda^2 t_1 + \lambda t_2 + t_3) w = 0, \quad (53)$$

with the notations

$$t_1(y) \equiv \frac{1}{v_d^2} \frac{h^2 - \varphi_s^2}{h^4} + \frac{2}{v_d} \frac{\varphi_s \tilde{\chi}_J}{h^4}, \quad (54)$$

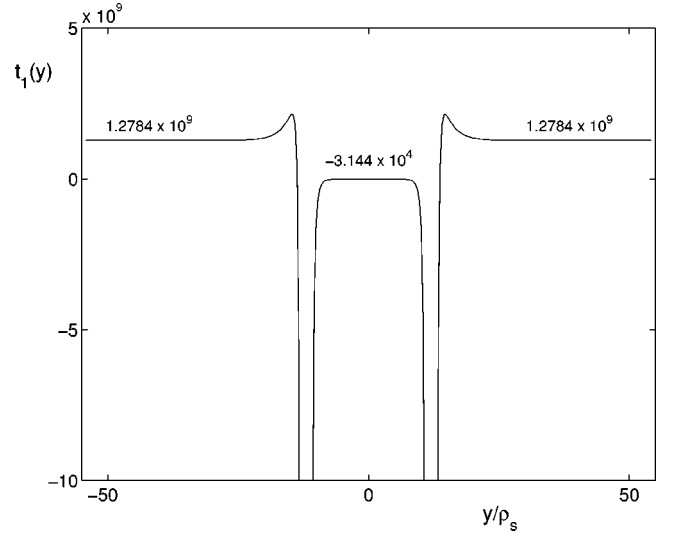

FIG. 2. The function $t_1(y)$ for a particular soliton velocity, $u = 1.725 v_d$.

$$t_2(y) \equiv -\frac{1}{v_d} \left(\frac{\partial \varphi_s}{\partial y} \right) \frac{2c - h}{h^3} + \frac{2}{v_d} \frac{\left(\frac{\partial \varphi_s}{\partial y} \right)}{h^3} \tilde{\chi}_J - \frac{1}{v_d} \frac{1}{h^2} \left(\frac{\partial \tilde{\chi}_J}{\partial y} \right), \quad (55)$$

$$t_3(y) \equiv -\frac{3}{4} \frac{1}{h^2} \left(\frac{\partial \varphi_s}{\partial y} \right)^2, \quad (56)$$

and

$$c \equiv \bar{k}_\perp^2, \quad (57)$$

$$h = c + \varphi_s.$$

The functions $t_i(y)$ are represented for $i=1,2$ in Figs. 2 and 3. The function

$$U(\lambda; y) \equiv \lambda^2 t_1 + \lambda t_2 + t_3 \quad (58)$$

has singularities at the points where h vanishes. We introduce the notation y_h for the location of the singularities, taking into account the symmetry around $y=0$, the center of the soliton

$$h(\pm y_h) = 0. \quad (59)$$

Since the soliton is very localized, the function U has very fast variations close to the singularities. The slow variation of the function $U(\lambda; y)$ over most of the space interval $(-L/2, +L/2)$ becomes very fast due to the growth of the absolute values of t_1 , t_2 , and t_3 near $\pm y_h$, on spatial intervals having an extension of the order of the spatial unit, i.e., ρ_s in physical terms. Since the physical model leading to our original equation cannot accurately describe the physical processes at such scales, we shall adopt the simplest approximation of U , assuming that it reaches infinite absolute value at points that are located within a distance of ρ_s of the actual positions of the singularities, $\pm y_h$. We have checked that the

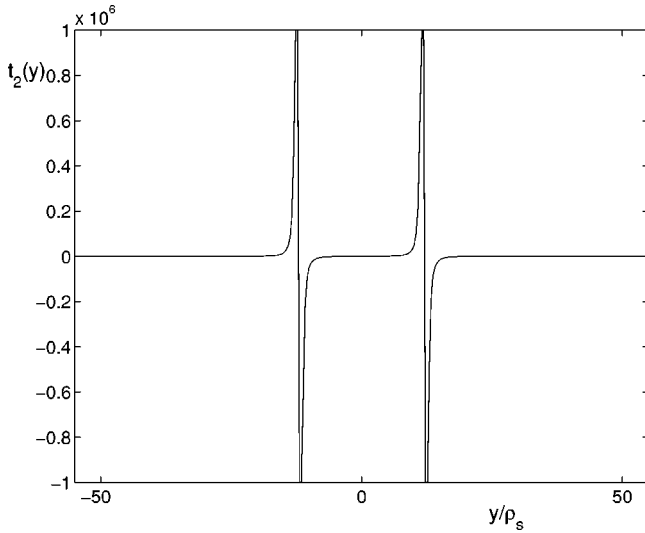

FIG. 3. The function $t_2(y)$ of the Eq. (53) for the same u .

exact position of the assumed *infinite* value of U has no significant impact on the final results, which can be explained by observing that $t_{1,2,3}$ will be integrated on. The total space interval is now divided into three domains: $(-L/2, -y_h)$ (external left), $(-y_h, y_h)$ (internal), and $(y_h, L/2)$ (external right). Here “internal” and “external” refer to the region approximately occupied by the soliton. The form of the function U imposes the function w to vanish at the limits of these domains. In a more general perspective, the fact that w behaves independently on each domain has a consequence with statistical mechanics interpretation: the generating functional (similar to any partition function) is obtained by integrating over the full space of the system’s physical configurations and behaves multiplicatively for any splitting of the whole function space into disjoint subspaces. In particular the functional integration over the space of functions $\delta\varphi$ and $\delta\chi$ actually consists of three functional integrations over the disjoint function subspaces corresponding to the three spatial domains. The fact that our physical model is restricted to spatial scales larger than ρ_s necessarily has an impact on the maximum number of eigenvalues λ_n that should be retained in the infinite product giving the determinant, but we shall not need to use this limitation.

For absolute values of the parameter λ greater than unity [which will be confirmed *a posteriori*, by the expressions (62) and (71) below], the three terms in the expression of U have very different contributions. The terms t_3 is practically negligible, and the term with t_1 is always much greater than t_2 in absolute value. In the following we consider separately the three domains.

On the “external left” domain, the function t_1 is positive. If we fix at zero the amplitude and the phase of w at the limit $-L/2$ the condition that the solution vanishes at $-y_h$ gives, for λ real,

$$\int_{-L/2}^{-y_h} dy' (\lambda^2 t_1 + \lambda t_2 + t_3)^{1/2} = 2\pi n. \quad (60)$$

In the integrand, the first term is factorized and, taking into account the relative magnitude of the terms, we expand the square root and obtain

$$\lambda_n^l \alpha_1 + \beta_1 + \frac{\gamma_1}{\lambda_n^l} = 2\pi n, \quad (61)$$

i.e.,

$$\lambda_n^l = \frac{2\pi n}{\alpha_1} \left(1 - \frac{\beta_1/(2\pi)}{n} \right), \quad (62)$$

where

$$\alpha_1 = \int_{-L/2}^{-y_h} dy' \sqrt{t_1(y')}, \quad (63)$$

$$\beta_1 = \int_{-L/2}^{-y_h} dy' \frac{t_2(y')}{\sqrt{t_1(y')}}, \quad (64)$$

$$\gamma_1 = \int_{-L/2}^{-y_h} dy' \frac{t_3(y')}{\sqrt{t_1(y')}}, \quad (65)$$

and γ_1 has been neglected. We note that β_1 is positive.

On the “external right” domain the function t_1 is positive but t_2 is negative. The condition on the phase is

$$\int_{y_h}^{L/2} dy' (\lambda^2 t_1 + \lambda t_2 + t_3)^{1/2} = 2\pi n', \quad (66)$$

and introduce similar notations

$$\alpha_2 = \int_{y_h}^{L/2} dy' \sqrt{t_1(y')} = \alpha_1, \quad (67)$$

$$\beta_2 = \int_{y_h}^{L/2} dy' \frac{t_2(y')}{2\sqrt{t_1(y')}} = -\beta_1, \quad (68)$$

$$\gamma_2 = \int_{y_h}^{L/2} dy' \frac{t_3(y')}{2\sqrt{t_1(y')}}. \quad (69)$$

The equation then becomes

$$\lambda_{n'}^r \alpha_2 + \beta_2 + \frac{\gamma_2}{\lambda_{n'}^r} = 2\pi n', \quad (70)$$

or

$$\lambda_{n'}^r = \frac{2\pi n'}{\alpha_2} \left(1 + \frac{\beta_1/(2\pi)}{n'} \right). \quad (71)$$

The infinite product of eigenvalues gives, for the “external” region [29]

$$\begin{aligned} \prod_n \lambda_n^l \prod_{n'} \lambda_{n'}^r &= \prod_n \left(\frac{2\pi n}{\alpha_1} \right)^2 \prod_n \left(1 - \frac{\beta_1^2/(2\pi)^2}{n^2} \right) \\ &= \frac{\sin(\beta_1/2)}{\beta_1/2} \prod_n \left(\frac{2\pi n}{\alpha_1} \right)^2. \end{aligned} \quad (72)$$

In the “internal” region, the function t_1 is negative. The relations between the magnitudes of the absolute values of the functions t_1 , t_2 , and t_3 are preserved. Then λ will be complex. Due to the antisymmetry of the function t_2 we can suppose that the unknown function w takes zero value at $y=0$. We introduce the notations

$$\alpha_c = \int_0^{y_h} dy' \sqrt{-t_1(y')}, \quad (73)$$

$$\beta_c = \int_0^{y_h} dy' \frac{t_2(y')}{2\sqrt{-t_1(y')}}, \quad (74)$$

$$\gamma_c = \int_0^{y_h} dy' \frac{t_3(y')}{2\sqrt{-t_1(y')}}, \quad (75)$$

which are *real* numbers. The condition

$$\lambda_n^i \alpha_c + \beta_c + \frac{\gamma_c}{\lambda_n^i} = 2\pi i n, \quad (76)$$

gives (after neglecting γ_c) for the complex number λ_n^i ,

$$\lambda_n^i = \alpha_c^{-1} (2\pi n) \left(1 + \frac{\beta_c^2}{(2\pi)^2 n^2} \right)^{1/2} \exp \left[-i \arctan \left(\frac{2\pi n}{\beta_c} \right) \right]. \quad (77)$$

The infinite product of these eigenvalues is

$$\begin{aligned} \prod_n \lambda_n^i &= \prod_n \alpha_c^{-1} (2\pi n) \exp \left[-i \arctan \left(\frac{2\pi n}{\beta_c} \right) \right] \\ &\times \prod_n \left(1 + \frac{\beta_c^2/(2\pi)^2}{n^2} \right)^{1/2}. \end{aligned} \quad (78)$$

The number β_c is smaller than unity and for large n the argument of the exponential will be more and more close to $-i\pi/2$. We make the approximation that the exponential can be replaced with $-i$. Then we obtain

$$\prod_n \lambda_n^i = \left[\frac{\sinh(\beta_c/2)}{\beta_c/2} \right]^{1/2} \prod_n \frac{(-i)2\pi n}{\alpha_c}. \quad (79)$$

On the “external” regions the functions t_1 , t_2 are not symmetrical around the center $y=0$ since the perturbed soliton develops a “tail” that is not symmetrical. However, we take this perturbation to be small and assume the same absolute value for the function β_1 on both external domains.

We remark that we remain with two quantities in which all the functional dependence on the current J is packed for “exterior” β_1 (hereafter denoted σ) and for “interior” β_c (hereafter denoted β).

$$\begin{aligned} Z_J &= \exp(iS_J) \left(\prod_n \frac{(2\pi)}{i} \left[\det \left(\frac{\delta^2 S_J}{\delta\varphi\delta\chi} \Big|_{\varphi_{J_s}, \chi_{J_s}} \right) \right]^{-1/2} \right) \\ &= \text{const} \exp(iS_J) \left[\frac{\beta/2}{\sinh(\beta/2)} \right]^{1/4} \left[\frac{\sigma/2}{\sin(\sigma/2)} \right]^{1/2}, \end{aligned} \quad (80)$$

where

$$\text{const} = \prod_n \left(\frac{(-i)\alpha_c}{2\pi n} \right)^{1/2} \frac{\alpha_1}{n} \quad (81)$$

will disappear after the normalizations required by the calculation of the correlations (see below).

V. CALCULATION OF THE CORRELATIONS

The two-point correlation can be obtained by a double functional differentiation at the external current J :

$$\langle \varphi(y_2) \varphi(y_1) \rangle = Z_J^{-1} \frac{\delta^2 Z_J}{i \delta J(y_2) i \delta J(y_1)} \Big|_{J=0}.$$

The main achievement of this approach is that it provides the explicit expression of the generating functional. We introduce the notations

$$A = A[J] \equiv \left[\frac{\beta/2}{\sinh(\beta/2)} \right]^{1/4}, \quad (82)$$

$$B = B[J] \equiv \left[\frac{\sigma/2}{\sin(\sigma/2)} \right]^{1/2}, \quad (83)$$

and drop the factor const; actually the latter depends on α_1 and α_c and thus on the current J and contributes to the functional derivatives. However, taking a formal limit N to the number of factors in Eq. (81) we find that the functional derivatives of α_1 and α_c give additive terms that vanish in the limit $N \rightarrow \infty$. Then we drop const since it disappears after dividing to Z_J and taking $J \equiv 0$. In this way Eq. (80) becomes

$$Z_J = \exp(iS_J) AB. \quad (84)$$

We calculate the functional derivatives,

$$\frac{\delta Z_J}{i \delta J(y_1)} = \left[\frac{\delta S_J}{\delta J(y_1)} + \frac{1}{A} \frac{\delta A}{i \delta J(y_1)} + \frac{1}{B} \frac{\delta B}{i \delta J(y_1)} \right] \exp(iS_J) AB. \quad (85)$$

We will also need the functional derivative at $J(y_2)$, with a similar expression. The second derivative,

$$\begin{aligned}
Z_J^{-1} \frac{\delta^2 Z_J}{i \delta J(y_2) i \delta J(y_1)} \Big|_{J=0} &= \frac{\delta S_J}{\delta J(y_2)} \frac{\delta S_J}{\delta J(y_1)} + \frac{\delta^2 S_J}{i \delta J(y_2) \delta J(y_1)} + \frac{1}{A} \frac{\delta A}{i \delta J(y_2)} \frac{\delta S_J}{\delta J(y_1)} + \frac{1}{B} \frac{\delta B}{i \delta J(y_2)} \frac{\delta S_J}{\delta J(y_1)} \\
&+ \frac{1}{A} \frac{\delta A}{i \delta J(y_1)} \frac{\delta S_J}{\delta J(y_2)} + \frac{1}{B} \frac{\delta B}{i \delta J(y_1)} \frac{\delta S_J}{\delta J(y_2)} + \frac{1}{A} \frac{\delta A}{i \delta J(y_1)} \frac{1}{B} \frac{\delta B}{i \delta J(y_2)} + \frac{1}{A} \frac{\delta A}{i \delta J(y_2)} \frac{1}{B} \frac{\delta B}{i \delta J(y_1)} \\
&+ \frac{1}{A} \frac{\delta^2 A}{i \delta J(y_2) i \delta J(y_1)} + \frac{1}{B} \frac{\delta^2 B}{i \delta J(y_2) i \delta J(y_1)}. \tag{86}
\end{aligned}$$

The detailed expressions of these terms are given in the Appendix. The terms are calculated numerically using the detailed expressions of φ_s , $\partial\varphi_s/\partial y$, $\tilde{\chi}_J$ and $\partial\tilde{\chi}_J/\partial y$. The contributions are represented in Figs. 4–7 and their sum in Fig. 8.

The first term reproduces the self-correlation of the soliton and represents the connection with the results of Ref. [11], with our particular simplifications: single soliton and fixed (nonrandom) position of its center. As can easily be seen, the first order functional derivatives of S_J to the current J reduce to the function φ_s calculated in the corresponding points. The term with the double functional derivative of the action represents the contribution to the self-correlation of the soliton due to a statistical ensemble of initial conditions, without drift waves. All mixed terms (i.e., containing both the action and one of the factors A or B) represent interaction between the perturbed soliton and the drift waves. The terms containing exclusively the factors A and/or B refers to the drift waves *in the presence* of the perturbed soliton.

VI. DISCUSSION AND CONCLUSIONS

The formulas obtained by functional differentiation of the generating functional are complicated and a numerical calculation is necessary. We chose a particular value of the soliton velocity (which also fixes its amplitude): $u = 1.725 v_d$ and let the variables y_1 and y_2 sample the one-dimensional volume of length $L = 0.2$ m. The physical parameters are chosen

such that $\rho_s \approx 10^{-3}$ m and $v_d \approx 571$ m/s. We recall that there are two particular symmetry limitations of our calculation. (1) The soliton center is assumed fixed (at $y = 0$), especially for avoiding the complicated problem of the *zero modes*. (2) Due to the asymmetry of the perturbed soliton tail the terms that results from the functional differentiation are also asymmetric. These are only limitations of our calculation and in no way reflect the reality of a isotropic motion of many solitons in a real turbulent plasma. In order to see to what extent our result can be useful for understanding the (much more complicated) real situation we will symmetrize these terms in the unique mode that is accessible to our one-dimensional calculation, i.e., take into account the mixing of perturbed solitons moving in the two directions on the line.

The amplitude of the modifications of the soliton depends on a parameter, which is the average time of interaction with the perturbation. This average time is comparable with the time required to cross L at a speed of v_d and is limited since the growth of the perturbation cannot exceed the soliton itself.

The figures are conventional representations of functions of two variables (y_1, y_2); they do not correspond to a two-dimensional geometry. For this reason it is not expected to have circular symmetry. The contributions to the correlation from the last two factors in Eq. (86) have amplitudes similar or less by a factor of few units, compared to the pure soliton. The factors coming from “internal” part are peaked and localized on the soliton extension while the “external” part

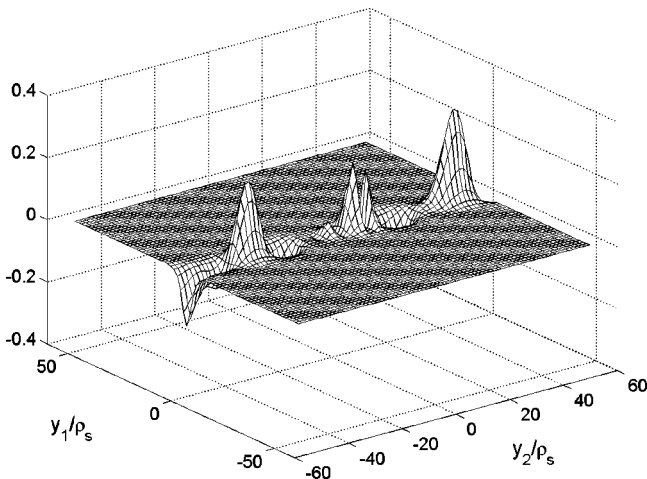

FIG. 4. The contribution to the two-point correlation from the term $B^{-1}[\delta B/\delta J(y_2)]A^{-1}[\delta A/\delta J(y_1)]$.

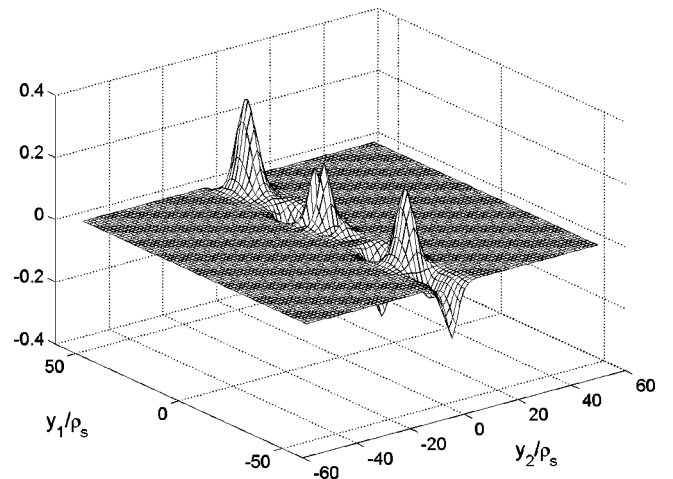

FIG. 5. The contribution to the two-point correlation from the term $A^{-1}[\delta A/\delta J(y_2)]B^{-1}[\delta B/\delta J(y_1)]$.

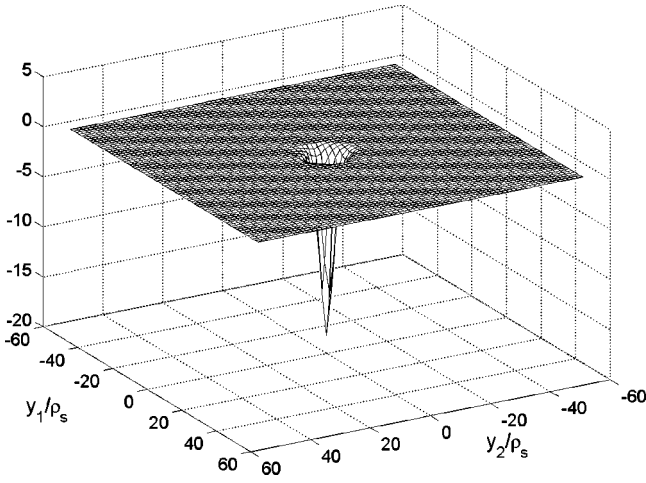

FIG. 6. The contribution to the two-point correlation from the term $A^{-1} \delta^2 A / [\delta J(y_2) \delta J(y_1)]$.

gives terms oscillating on (y_1, y_2) . In wave number space, there are contributions to both low- k and high- k regions. The spectrum of an unperturbed soliton is smooth and monotonously decreasing from the peak value at $\mathbf{k}=\mathbf{0}$, as shown in Fig. 9. Figure 10 shows much more structure. In the low- k part there are many local peaks, an effective manifestation of the periodic character of the terms [as shown by Eq. (72)]. This arises from the discrete nature of the eigenvalues, which is induced by the second order differential operator and the vanishing of the eigenmodes at the positions of the singularities $\approx \pm y_h$. The singularities are generated by the vanishing of the norm of the operator $\hat{\alpha}$, which makes ambiguous the assumption of propagating wave character, $\partial_t = -v_d \partial_y$. The large- k part mainly reflects the structure of the small-scale shape perturbation of the soliton, coming from β -related terms. Figure 11 is a (k, ω) spectrum obtained from $\omega - ku = 0$ and repeating the calculations for various soliton velocities $u_{\max} > u > v_d$. Although we cannot afford high u_{\max} since the expressions of $t_{1,2,3}(y)$ depend on the assumption $u \gtrsim v_d$, we remark local peaks in contrast to the “pure soliton” result of Ref. [11].

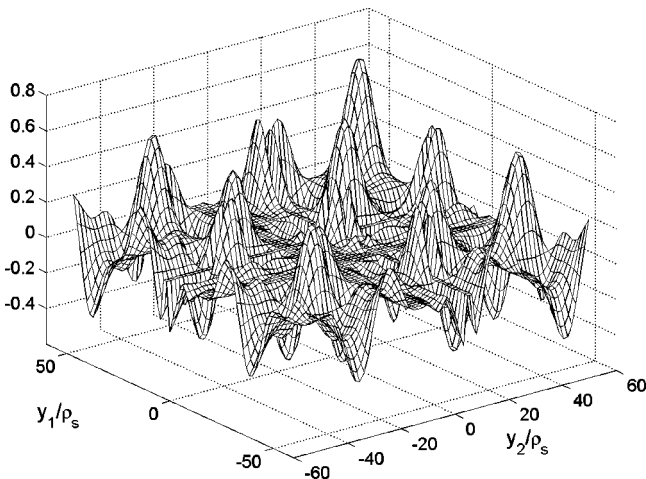

FIG. 7. The contribution to the two-point correlation from the term $B^{-1} \delta^2 B / [\delta J(y_2) \delta J(y_1)]$.

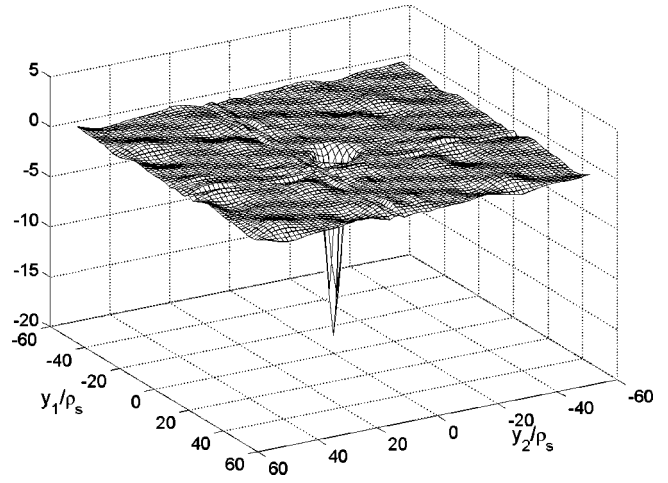

FIG. 8. The perturbation to the correlation in physical space.

For simplicity we have assumed a single soliton. However the calculation can be readily extended to the multisoliton case, considering instead of Eqs. (29) and (31) sums over many individual soliton solutions with different velocities and positions of the centers. These sums replace the functions φ_{J_s} and χ_{J_s} in the expressions of the operators $\hat{\alpha}$, $\hat{\beta}$, and $\hat{\gamma}$. If the velocities are all greater but not too different from v_d the change of variables to the referential moving with v_d [described in the paragraph below Eq. (45)] will leave a very slow time variation that eventually may be treated perturbatively. Many solitons will also generate many singularities arising from the vanishing of the function h , and this will factorize the space of functions and correspondingly the generating functional. It will become, however, possible to consider random positions and random velocities and average them with distribution functions for the Gibbs ensemble, as in [11]. This is very simple with the first term of Eq. (86), which should be compared directly with Ref. [11], but technically very difficult with the terms involving functional derivatives of A and/or B .

The first results suggest that the non-Gaussianity at the

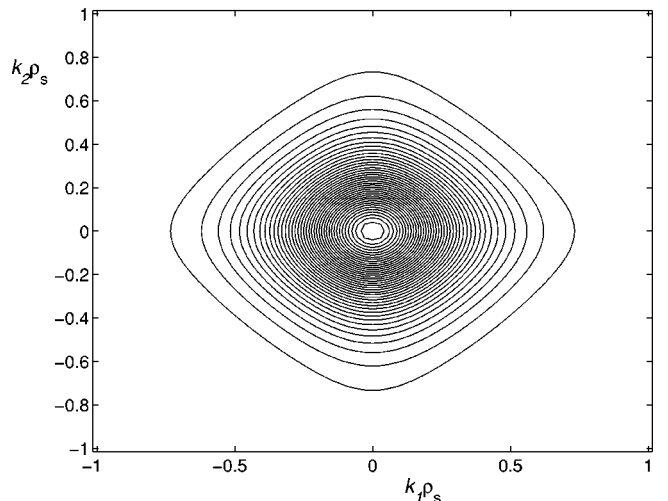

FIG. 9. Contour plot of the vortex (k_1, k_2) spectrum.

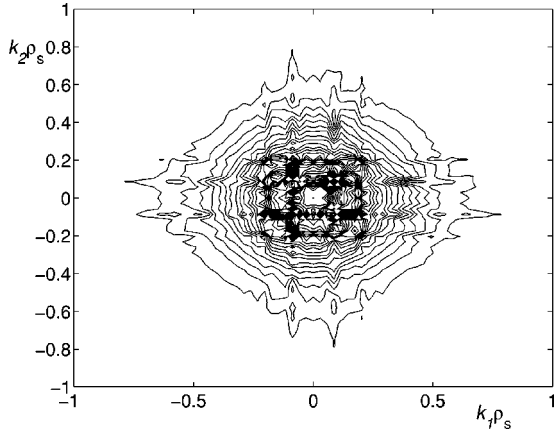

FIG. 10. Contour plot of the spectrum of the vortex perturbed by the turbulent drift waves.

plasma edge can be explained by the presence of coherent structures. The contribution of avalanches to the deviation from the Gaussian statistics cannot be excluded but, as shown for self-organized systems [31], they have a scaling that should be easily recognized, at least in frequency domain.

In conclusion we have developed an approach that allows us to calculate the statistical properties of a coherent structure in a turbulent background. Compared to the standard renormalization, this approach is at the opposite limit in what concerns the relation ‘‘coherent structure/wave turbulence,’’ highlighting the coherent structure. However, it offers comparatively greater possibilities for the extension of this studies to the more realistic problem of cascading wave turbulence mixed with rising and decaying coherent structures.

ACKNOWLEDGMENTS

The authors are indebted to J. H. Misguich and R. Balescu for many stimulating and enlightening discussions. F.S. and M.V. gratefully acknowledge the support and hospitality of

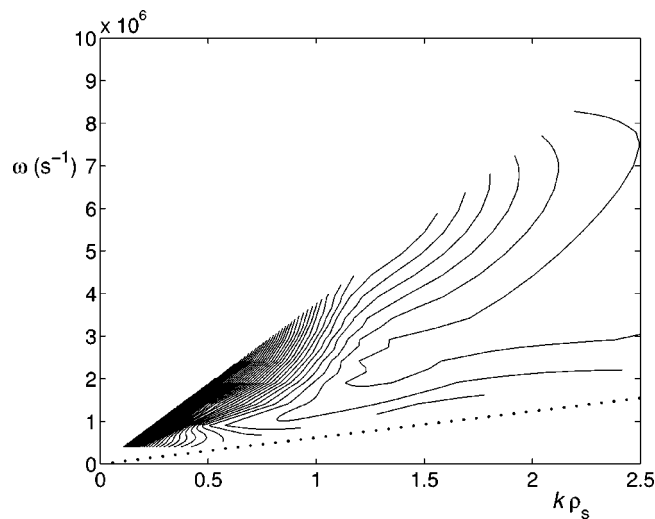

FIG. 11. The contour plot of the frequency-wave number spectrum, with $\omega - ku = 0$.

the D epartement de Recherche sur la Fusion Control ee, Cadarache, France. This work has been partly supported by the NATO Linkage Grant Nos. CRG.LG 971484 and PST.CLG.977397.

APPENDIX: EXPLICIT EXPRESSIONS FOR THE FUNCTIONAL DERIVATIVES

We shall first concentrate on the derivatives of the two factors A and B ,

$$\begin{aligned} \frac{\delta B}{\delta J(y_1)} &= \frac{\delta}{\delta J(y_1)} \left[\frac{\sigma/2}{\sin(\sigma/2)} \right]^{1/2} = \frac{1}{4} \left[\frac{1}{\sin(\sigma/2)} + \frac{\sigma \cos(\sigma/2)}{2 \sin^2(\sigma/2)} \right] \\ &\times \left[\frac{\sigma/2}{\sin(\sigma/2)} \right]^{-1/2} \left(\frac{\delta \sigma}{\delta J(y_1)} \right) \end{aligned} \quad (\text{A1})$$

and

$$\begin{aligned} \frac{\delta^2 B}{\delta J(y_2) \delta J(y_1)} &= \frac{\delta^2}{\delta J(y_2) \delta J(y_1)} \left[\frac{\sigma/2}{\sin(\sigma/2)} \right]^{1/2} \\ &= \left\{ -\frac{1}{8} \left[\frac{\sigma/2}{\sin(\sigma/2)} \right]^{1/2} \frac{1 + \cos^2(\sigma/2)}{\sin^2(\sigma/2)} \right. \\ &\quad \left. - \frac{1}{16} \left[\frac{\sigma/2}{\sin(\sigma/2)} \right]^{-3/2} \left[\frac{1}{\sin(\sigma/2)} \right. \right. \\ &\quad \left. \left. + \frac{\sigma \cos(\sigma/2)}{2 \sin^2(\sigma/2)} \right]^2 \right\} \left(\frac{\delta \sigma}{\delta J(y_2)} \right) \left(\frac{\delta \sigma}{\delta J(y_1)} \right) \\ &\quad + \frac{1}{4} \left[\frac{\sigma/2}{\sin(\sigma/2)} \right]^{-1/2} \left[\frac{1}{\sin(\sigma/2)} \right. \\ &\quad \left. + \frac{\sigma \cos(\sigma/2)}{2 \sin^2(\sigma/2)} \right] \left(\frac{\delta^2 \sigma}{\delta J(y_2) \delta J(y_1)} \right). \end{aligned} \quad (\text{A2})$$

For the exterior domains,

$$\sigma = \sigma_0 + \tilde{\sigma}_{J1} + \tilde{\sigma}_{J2} \quad (\text{A3})$$

with

$$\sigma_0 = \frac{1}{2} \int_{-L/2}^{-y_h} dy' \left[- \left(\frac{\partial \varphi_s}{\partial y} \right) \frac{\frac{2c}{h} - 1}{(h^2 - \varphi_s^2)^{1/2}} \right], \quad (\text{A4})$$

$$\begin{aligned} \tilde{\sigma}_{J1} &= \frac{1}{2} \int_{-L/2}^{-y_h} dy' \left[\left(\frac{\partial \varphi_s}{\partial y} \right) \frac{1}{h(h^2 - \varphi_s^2)^{1/2}} \right. \\ &\quad \left. \times \left(2 - \frac{\varphi_s(2c - h)}{h^2 - \varphi_s^2} \right) \tilde{\chi}_J^{ext} \right], \end{aligned} \quad (\text{A5})$$

$$\tilde{\sigma}_{J2} = \frac{1}{2} \int_{-L/2}^{-y_h} dy' \left[- \frac{1}{(h^2 - \varphi_s^2)^{1/2}} \left(\frac{\partial \tilde{\chi}_J^{ext}}{\partial y} \right) \right]. \quad (\text{A6})$$

We have the following connected expressions:

$$\frac{\delta\sigma}{\delta J(y_1)} = \frac{\delta\tilde{\sigma}_{J1}}{\delta J(y_1)} + \frac{\delta\tilde{\sigma}_{J2}}{\delta J(y_1)}, \quad (A7)$$

$$\begin{aligned} \frac{\delta\tilde{\sigma}_{J1}}{\delta J(y_1)} &= \frac{1}{2} \int_{-L/2}^{-y_h} dy' \left(\frac{\partial\varphi_s}{\partial y} \right) \frac{1}{h(h^2 - \varphi_s^2)^{1/2}} \left(2 - \frac{\varphi_s(2c-h)}{h^2 - \varphi_s^2} \right) \\ &\times \left(\frac{\delta\tilde{\chi}_J^{ext}}{\delta J(y_1)} \right), \end{aligned} \quad (A8)$$

$$\frac{\delta\tilde{\sigma}_{J2}}{\delta J(y_1)} = \frac{1}{2} \int_{-L/2}^{-y_h} dy' \frac{(-1)}{(h^2 - \varphi_s^2)^{1/2}} \frac{\delta}{\delta J(y_1)} \left(\frac{\partial\tilde{\chi}_J^{ext}}{\partial y} \right), \quad (A9)$$

and

$$\frac{\delta^2\sigma}{\delta J(y_2)\delta J(y_1)} = \frac{\delta^2\tilde{\sigma}_{J1}}{\delta J(y_2)\delta J(y_1)} + \frac{\delta^2\tilde{\sigma}_{J2}}{\delta J(y_2)\delta J(y_1)}, \quad (A10)$$

$$\begin{aligned} \frac{\delta^2\tilde{\sigma}_{J1}}{\delta J(y_2)\delta J(y_1)} &= \frac{1}{2} \int_{-L/2}^{-y_h} dy' \left(\frac{\partial\varphi_s}{\partial y} \right) \frac{1}{h(h^2 - \varphi_s^2)^{1/2}} \\ &\times \left(2 - \frac{\varphi_s(2c-h)}{h^2 - \varphi_s^2} \right) \left(\frac{\delta^2\tilde{\chi}_J^{ext}}{\delta J(y_2)\delta J(y_1)} \right), \end{aligned} \quad (A11)$$

$$\begin{aligned} \frac{\delta^2\tilde{\sigma}_{J2}}{\delta J(y_2)\delta J(y_1)} &= \frac{1}{2} \int_{-L/2}^{-y_h} dy' \frac{(-1)}{(h^2 - \varphi_s^2)^{1/2}} \frac{\delta^2}{\delta J(y_2)\delta J(y_1)} \\ &\times \left(\frac{\partial\tilde{\chi}_J^{ext}}{\partial y} \right). \end{aligned} \quad (A12)$$

For the ‘‘interior’’ region, the derivatives of A , (which are straightforward) will require the calculation of the derivatives of β .

$$\beta = \frac{1}{2} \int_0^{y_h} dy \frac{-\frac{1}{v_d} \left(\frac{\partial\varphi_s}{\partial y} \right) \frac{2c-h}{h^3} + \frac{2}{v_d} \frac{1}{h^3} \left(\frac{\partial\varphi_s}{\partial y} \right) \tilde{\chi}_J^{int} - \frac{1}{v_d} \frac{1}{h^2} \frac{d\tilde{\chi}_J^{int}}{dy}}{\left(\frac{1}{v_d^2} \frac{\varphi_s^2 - h^2}{h^4} \right)^{1/2} \left(1 - \frac{2\varphi_s}{\varphi_s^2 - h^2} \tilde{\chi}_J^{int} \right)^{1/2}}.$$

The function $\tilde{\chi}_J^{int}$ and its derivative are present in the expression of β :

$$\beta = \beta_0 + \tilde{\beta}_{J1} + \tilde{\beta}_{J2},$$

$$\beta_0 = \frac{1}{2} \int_0^{y_h} dy \left[- \left(\frac{\partial\varphi_s}{\partial y} \right) \frac{2c-h}{h(\varphi_s^2 - h^2)^{1/2}} \right],$$

$$\tilde{\beta}_{J1} = \frac{1}{2} \int_0^{y_h} dy \left[\left(\frac{\partial\varphi_s}{\partial y} \right) \frac{1}{h(\varphi_s^2 - h^2)^{1/2}} \left(2 - \frac{\varphi_s(2c-h)}{\varphi_s^2 - h^2} \right) \tilde{\chi}_J^{int} \right],$$

$$\tilde{\beta}_{J2} = \frac{1}{2} \int_0^{y_h} dy \left[- \frac{1}{(\varphi_s^2 - h^2)^{1/2}} \left(\frac{d\tilde{\chi}_J^{int}}{dy} \right) \right],$$

and the derivatives at J are easily calculated, as for σ .

The formulas above need to specify the expression of the functions $\tilde{\chi}_J^{ext}$, $\partial\tilde{\chi}_J^{ext}/\partial y$, and of their functional derivatives. We use the results of the analysis carried out by Karpman.

[1] F. Spineanu and M. Vlad, Phys. Rev. Lett. **84**, 4854 (2000).
 [2] D. Fyfe, D. Montgomery, and G. Joyce, J. Plasma Phys. **17**, 369 (1976).
 [3] D. Biskamp, Phys. Rep. **237**, 179 (1994).
 [4] G.C. Craddock, P.H. Diamond, and P.W. Terry, Phys. Fluids B **3**, 304 (1991).
 [5] X.N. Su, W. Horton, and P.J. Morrison, Phys. Fluids B **3**, 921 (1991).
 [6] M. Kono and E. Miyashita, Phys. Fluids **31**, 326 (1988).
 [7] T. Tajima, W. Horton, P.J. Morrison, S. Shutkaker, T. Kamimura, K. Mima, and Y. Abe, Phys. Fluids B **3**, 938 (1991).
 [8] R.D. Hazeltine, D.D. Holm, and P.J. Morrison, J. Plasma Phys.

34, 103 (1985).
 [9] J. Nycander, Phys. Fluids B **3**, 931 (1991).
 [10] R. Kinney, J.C. McWilliams, and T. Tajima, Phys. Plasmas **2**, 3623 (1995).
 [11] J.D. Meiss and W. Horton, Phys. Fluids **25**, 1838 (1982).
 [12] J.P. Boyd and B. Tan, Chaos, Solitons Fractals **9**, 2007 (1998).
 [13] J.D. Meiss and W. Horton, Phys. Fluids **26**, 990 (1983).
 [14] W. Horton, Phys. Rep. **192**, 1 (1990).
 [15] P.W. Terry and P.H. Diamond, Phys. Fluids **28**, 1419 (1985).
 [16] J.A. Krommes, in *Handbook of Plasma Physics*, edited by A.A. Galeev and R.N. Sydan (North-Holland, Amsterdam, 1984), Vol. 2, Chap. 5.5, p. 183.
 [17] J.H. Misguich and R. Balescu, Plasma Phys. **24**, 284 (1982).

- [18] W.Y. Zhang and R. Balescu, *Plasma Phys. Controlled Fusion* **29**, 993 (1987); **29**, 1019 (1987).
- [19] W. Horton, J. Liu, J.D. Meiss, and J.E. Sedlak, *Phys. Fluids* **29**, 1004 (1986).
- [20] T. Schafer and E.V. Shuryak, *Rev. Mod. Phys.* **70**, 323 (1998).
- [21] P.C. Martin, E.D. Siggia, and H.A. Rose, *Phys. Rev. A* **8**, 423 (1973).
- [22] R.V. Jensen, *J. Stat. Phys.* **25**, 183 (1981).
- [23] D.J. Amit, *Field Theory, the Renormalization Group and Critical Phenomena* (World Scientific, Singapore, 1984).
- [24] F. Spineanu, M. Vlad, and J.H. Misguich, *J. Plasma Phys.* **51**, 113 (1994).
- [25] F. Spineanu and M. Vlad, *J. Plasma Phys.* **54**, 333 (1995).
- [26] G. Eilenberger, *Solitons*, Springer Series in Solid-State Sciences Vol. 19 (Springer, Berlin, 1981).
- [27] P.G. Drazin and R.S. Johnson, *Solitons: an Introduction*, Cambridge Texts in Applied Mathematics Vol. 3 (Cambridge University Press, Cambridge, 1989).
- [28] V.I. Karpman, *Phys. Scr.* **20**, 462 (1979).
- [29] I.S. Gradshtein and I.M. Ryzhik, *Table of Integrals, Series and Products* (Academic Press, London, 1980), formulas 8.322 and 1.431.1.
- [30] F. Spineanu and M. Vlad, *Phys. Plasmas* **4**, 2106 (1997).
- [31] T. Hwa and M. Kardar, *Phys. Rev. A* **45**, 7002 (1992).